

FOODEX JAPAN 2027 Initiatives

- 1 GATEWAY of ASIA**
Where the world meets Asia
- 2 Establish new zones:**
HOT & SPICY, NOODLE, FOOD INGREDIENTS
- 3 Increase in PARTICIPATING COUNTRIES & Strengthening GLOBAL FOOD PROMOTION**

*Some programs might be changed without notice.

The Largest Food & Beverage Trade Show in Asia!

Expected Show Scale *() indicates the numbers in FOODEX JAPAN 2026.

Exhibitors
3,000+

Domestic

1,000+
Companies

(1,112 Companies)



Overseas

2,000+
Companies

(2,126 Companies)



Booths

4,000+

(4,026 Booths)

Visitors
90,000+



80+ Countries & Regions Visiting

Number of Visitors in 2026

By Industry Sector Visitors in Total **73,842** (72,151)

● Trading/Wholesale	23,763 (23,252)
● Manufacturer, Producer	16,235 (16,030)
● Food Service	13,783 (12,998)
● Retail	10,977 (11,063)
● Hotel, Banquet & Leisure	2,988 (2,187)
● Government, Association, Specialist	1,886 (1,752)
● Machinery Manufacturer	1,753 (1,662)
● Logistics	1,223 (1,061)
● Press	591 (598)
● Others	643 (1,548)

*() indicates the numbers in FOODEX JAPAN 2025.

Cost

● Basic Booth Plan (1 booth = 2.97m x 2.97m x 2.7m)

Early Bird JPY473,000 / booth

Final JPY550,000 / booth

*For Package Plan, please refer to another pamphlet for details.

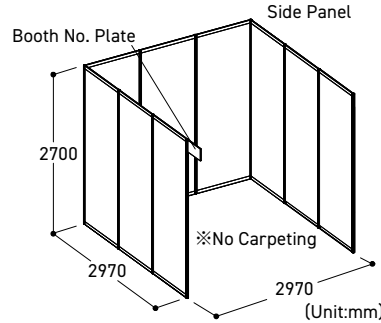

Including:

- Floor space
- Side and Back partitions.

Electrical Facilities

All main electrical installation work, secondary electrical installation work, and electricity usage charges shall be borne by the exhibitors.

● National Pavilion *Individual exhibitors are not eligible to apply

JPY66,000 / m² (9m² at minimum)

*The fee is also including pavilion services.

*Overseas Exhibitor Processing Fee of JPY4,400 will be charged.

*All prices on the above are including 10% consumption tax.

*Booth location will be determined by the Secretariat.

NOTE: Exhibitor is responsible for stand construction, carpeting and equipment rentals.

Overall Schedule

2026

Category Zone

Jul 31

Early bird application deadline

Sep 25

Final application deadline

Oct 30

Early bird payment deadline

Final payment deadline

National Pavilion

Sep 25

Application deadline

Oct 30

Payment deadline

Late Nov

Booth location opens

2027

Jan 2027

Various applications deadline

※Refer to the Exhibitor's MyPage

Mar 6-8

Move-In period

Mar 9-12

FOODEX JAPAN '27

Mar 12

Move - out day

FOODEX JAPAN Secretariat

C/O Japan Management Association

Tel: +81-3-3434-3453

E-mail: foodexglobal@jma.or.jp

For inquiry



EXHIBITION INFORMATION



The 52nd International Food and Beverage Exhibition

FOODEX JAPAN 2027

52 国際食品・飲料展

DATE

2027

March 9 (Tue) - **12** (Fri)

10:00-17:00 (Until 16:30 on final day)

VENUE

Tokyo Big Sight

East Exhibition Halls 1-8

West Exhibition Halls 1-4

DEADLINE

Early Bird **July 31** (Fri), 2026

Final **September 25** (Fri), 2026



FOODEX JAPAN

Search

<https://www.jma.or.jp/foodex/en/>



Expected Floor Plan

East Exhibition Halls 1-8

National Pavilion

Japanese Importer

World Food

FOODEX Frozen

FROZEN Sweets & Ice Cream

FROZEN Machines & Technology

FROZEN FRESH FOOD

FROZEN Processed Food

FOODEX TECH

Food x AI

Logistics

Food Safety

Publication/Consultant

Startup

NEW!

Package Innovation

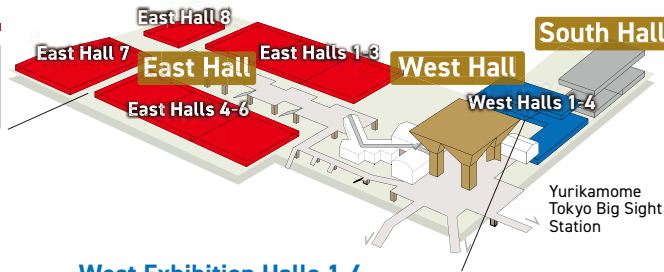

West Exhibition Halls 1-4

Exports from Japan

Export Support Service

Local Specialties in Japan

Agricultural Food

Meat

Seafood

Sweets & Snacks

Processed Food

Condiments/Seasoning

Beverage

FOODEX WINE

SAKE JAPAN

Halal, Vegan, Kosher

Organic

Plant Based / Alternative Food

Chilled Food

Healthcare

NEW!

HOT & SPICY

NEW!

Food Ingredients

NEW!

Noodle

List of Exhibiting Countries & Regions

76 countries & regions exhibited in 2026!

- ARGENTINA
- ARMENIA
- AUSTRALIA
- AZERBAIJAN
- BELGIUM
- BOLIVIA
- BRAZIL
- CAMBODIA
- CANADA
- CHILE
- CHINA
- COLOMBIA
- COSTA RICA
- CZECH
- DENMARK
- ECUADOR
- EGYPT
- ESTONIA
- ETHIOPIA
- EU
- FINLAND
- FRANCE
- GEORGIA
- GERMANY
- GHANA
- GREECE
- GUATEMALA
- HONG KONG
- HUNGARY
- INDIA
- INDONESIA
- IRELAND
- ISRAEL
- ITALY
- JAPAN
- KENYA
- KOREA
- LATVIA
- LITHUANIA
- MADAGASCAR
- MALAYSIA
- MAURITIUS
- MEXICO
- MOLDOVA
- MONGOLIA
- MOROCCO
- NETHERLANDS
- NEW ZEALAND
- NIGERIA
- NORWAY
- PAKISTAN
- PERU
- PHILIPPINES
- POLAND
- PORTUGAL
- ROMANIA
- SAUDI ARABIA
- SERBIA
- SINGAPORE
- SLOVENIA
- SOUTH AFRICA
- SPAIN
- SRI LANKA
- SUDAN
- SWEDEN
- SWITZERLAND
- TAIWAN
- THAILAND
- TURKEY
- U.A.E.
- U.K.
- U.S.A.
- UGANDA
- UKRAINE
- URUGUAY
- VIETNAM

Pre-scheduled Business Matching

RECOMMEND!

FREE SERVICE



14,521

Registered Business Meetings



282

Buyers (Domestic & Overseas)

215 Overseas buyers were invited from **34** countries & regions



List of Japanese Hosted Buyers in FOODEX JAPAN 2026

- AEON RETAIL
- AIT FINE FOOD
- AKTY TRADING GMBH
- ASSOCIATE & UNITED DISTRIBUTORS
- ATTI INTERNATIONAL
- AZUMA FOODS (CANADA)
- BELC
- BIANCA MARIE PASCUAL FOOD SERVICES
- BIG C (HK)
- BINH MINH FOOD IMPORT EXPORT
- BIO C' BON JAPON
- BRAND FRESH (HONG KONG)
- CAMEI
- CENTRAL BOEKI U.S.A.
- CENTRAL FOOD RETAIL
- CHENG PU ENTERPRISE
- COMINPORT DISTRIBUCION S.L.U.
- CONTENTO HOLDINGS
- DAI EI TRADING
- DAIMARU MATSUZAKAYA DEPARTMENT STORES
- DAISHO (THAILAND)
- DAISHO FOOD M SDN BHD
- DOLLARS WAREHOUSE
- DV NEVADA
- EAT & FOODS
- EBISU FOODS
- ELAND FARM & FOOD
- ENEOS MATERIAL TRADING
- FAIRPRICE GROUP
- FAMILY INTERNATIONAL
- FINO FOODS AUS
- FOCAL MARKETING SDN BHD
- FOODGEARS INDUSTRIAL INTERNATIONAL
- FUKUDAYA DEPARTMENT STORE
- GENKY
- GINZA COZY CORNER
- GLOBAL-DINING
- GS RETAIL
- HELLO SHOP AUSTRALIA
- HOKKA HOKKA TEI SOHONBU
- HONG KONG KURIYA
- HOP HING LOONG
- HORECA ASIAN FOOD
- HOT PALETTE
- HRT NEW OTANI
- HUANG JU FOOD (INTERNATIONAL)
- INTERCHAMP TRADING
- JALUX
- JAPAN MART 2014
- JIWOO CORPORATION
- JONDA INTERNATIONAL
- JP-MEDIC
- KA FER ZENTRALEINKAUF UND LOGISTIK GMBH
- KATAGIRI
- KOBE-YA SHOKUJIN KOGYO
- KOREA SEVEN
- KYOTO BEVERAGES PRIVATE
- LA SPECIALTY PRODUCE
- LEMAY DISTRIBUTION
- LOTTE SHOPPING
- LUCKY DUCK FOOD
- MASH BEAUTY LAB
- MITSUI & CO. (HONG KONG)
- NATURAL NATURAL
- NICHIRYU
- NIPPON HOTEL
- NIPPON PRODUCTS
- PARADISE HOTEL BUSAN
- PARADISE SEGASAMMY
- PARNAS HOTEL
- PERFECT PLAN (HONG KONG)
- ROYAL HOTEL
- SAKURAYA FOODS
- SAMKYOUNG F.S.
- SENSHUKAI
- SHIBATAYA AUSTRALIA
- SIMPLE MART RETAIL
- SPC GFS
- SUMMIT
- TAZAKI FOODS

Exhibitor Survey

*Only Overseas Exhibitors

87%

Exhibitor Satisfaction with the Exhibitor

80%

Exhibitor Satisfaction with Visitors

83%

Leads for Future Cooperation